

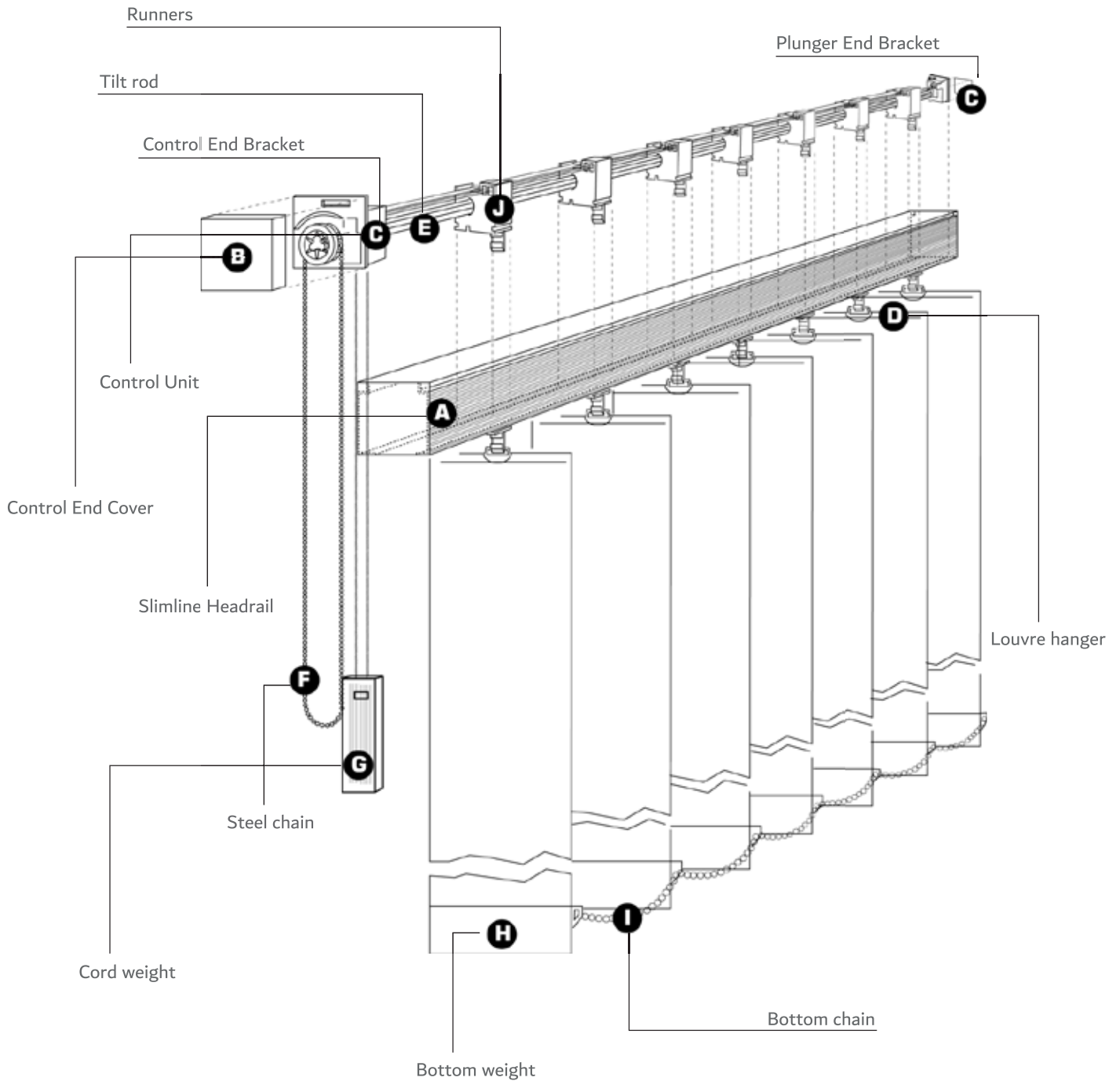

SLIMLINE TECHNICAL DRAWING



STANDARD SLIMLINE HAIDRAIL SYSTEM

Slimline Headrail

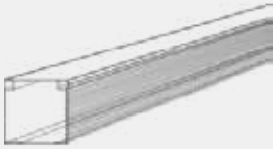

Control End Cover – covers the operating wheel and chain

Control End Cover

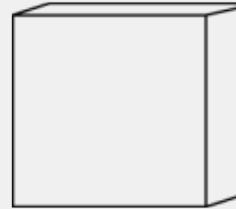

Control End Cover – covers the operating wheel and chain

Control Unit and idle End

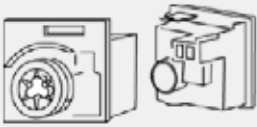

Control Unit and idle End, secures the tilt rod and by way of operating wheel and chain rotates the worm gear in each runner. Made of engineering plastic with good bearing.

Louvre Hanger



Louvre hanger – moulded plastic suitable for J or H hooks.

Tilt Rod



Aluminium mill finish tilt rod 6mm 3 prong type.

Metal Chain



3mm Nickel plated steel chain with connector.

Cord Weight

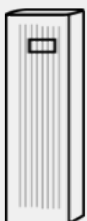

Aluminium mill finish tilt rod 6mm 3 prong type.

Bottom Weight

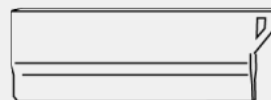

Moulded bottom weight in barium filled polypropylene aprox weight for 89 mm 30grammes.

STANDARD SLIMLINE HAIDRAIL SYSTEM

Bottom Chain



Bottom chain – can be moulded plastic on polyester cord or nickel plated steel chain with moulded clips to secure to bottom weights.

Runner Spacer

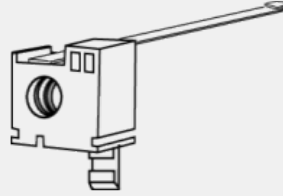

First runner spacer which clips over tilt rod and gives the spacing for the first runner

VOUGE SYSTEM TECHNICAL DRAWING

With Cord & Chain Operation

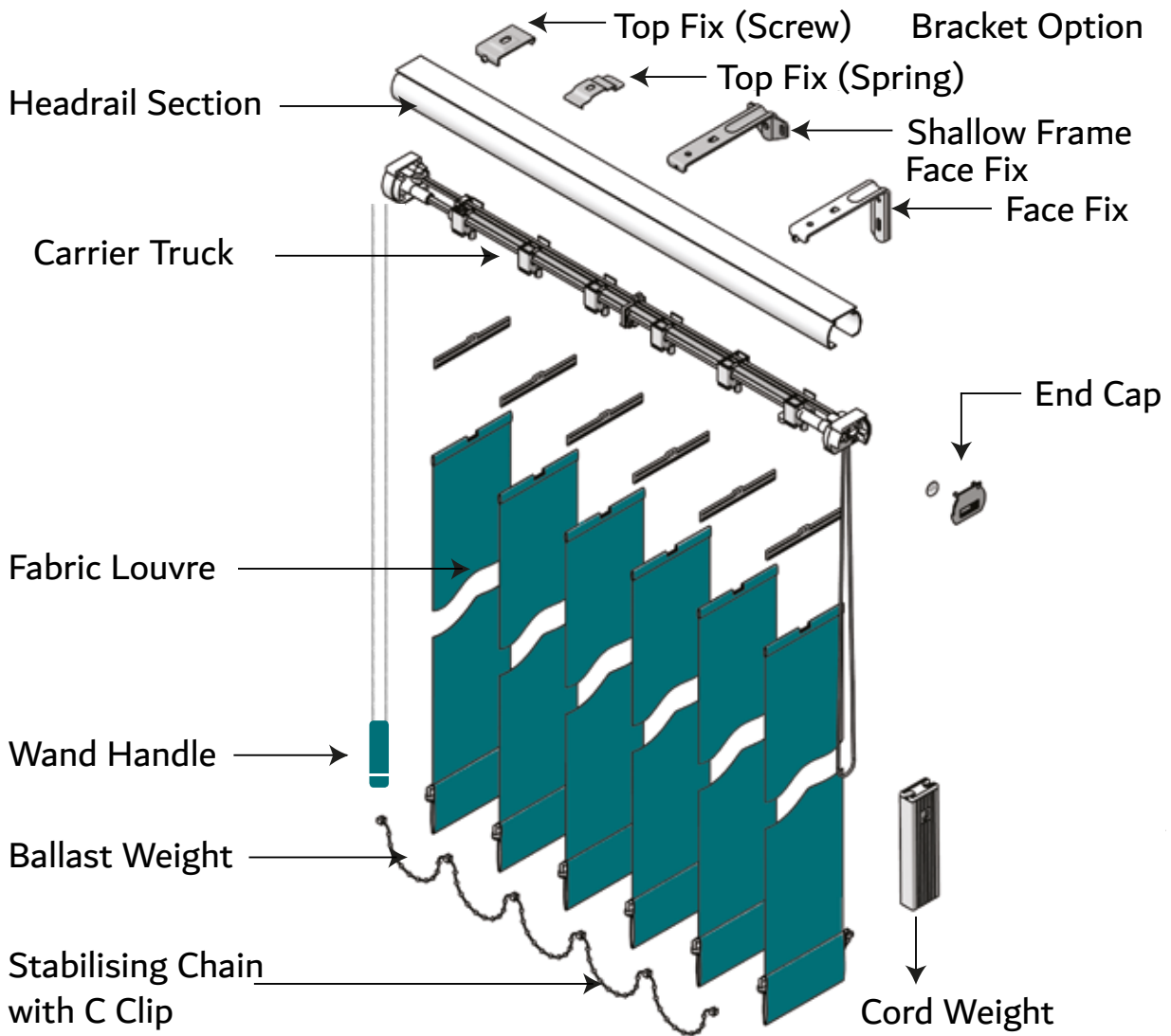

GENERAL APPLICATIONS

Vertical blinds incorporating the Vogue headrail system provide a contemporary and extremely practical commercial installation and are available from approved manufacturers worldwide. It is a robust and reliable system that has been specified for over 25 years.

The system is easily fitted and provides an extremely efficient method of light control. A large range of attractive flame retardant fabrics, and some featuring anti-glare SPC® and blackout coatings make these blinds the ideal choice for projects large or small. The fabrics are designed specifically for window blinds.

CARRIER TRUCKS

To ensure a positive and smooth operation within the headrail, all carriers are manufactured using prime quality plastic materials. This also provides durability and protection from embrittlement and UV rays. The gears in the carrier trucks that rotate the louvres are self-aligning with limit stops. This allows louvre rotation to 185°, which ensures an efficient closure without strain on the mechanism. The spacing between the carrier trucks is controlled by high-grade stainless steel spacer links. The standard spacing is either 77mm for 89mm louvers or 115mm for 127mm louvres, although alternative spacing options are available. UV stabilised louvre hangers are manufactured using Nylon No. 6 plastic.

OPERATION

Operation is by either No 6 size chain or a tilt and draw wand control. Vogue tracks are smooth running and robust. The components are made in aluminium, prime plastic or stainless steel. The design of the components minimises damage caused by operator misuse.

MAINTENANCE

All of the Vogue components are manufactured using aluminium, plastic or stainless steel. They do not present any corrosion problems in normal environments. The system has been designed for a smooth operation, together with a rigidity to prolong the window blind's working life. However any damage which does occur, can normally be rectified on site.

LOUVRES

Available in 89mm width. All louvres are weighted and have the option to be interlinked front and back with ball and 'C' clip connectors either in white or black, alternatively sewn in weights are available.

VOUGE HEADRAIL

The Vogue aluminium headrail extrusion is made from prime aluminium and is available in white and brown powder coated, silver anodised or polished black and champagne, which makes it corrosion resistant. Brackets are zinc plated or powder coated and manufactured with a strengthening crease for increased strength and safety.

White (White Trucks)



Piano Black (Black Trucks)



Brown (Black Trucks)



Brushed Steel (Black Trucks)



Graphite (Black Trucks)



Champagne Gold (Black Trucks)



Note : Black components are default on all headrail colours except for white in that instance white components are default.

VOGUE COMPONENTS

Headrail Section

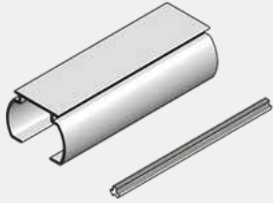

Slimline Vogue® Headrail

100% aluminium Dimensions: 38.5mm (1 1/2") x 28mm (1 1/8") Lengths: 5m (5.5 yard) maximum Colour: white, brown, silver, gold or black

Tilt Rod
Aluminium

Louvre Ballast Weights



Ballast Weights, Moulded,
Compact 89mm,
Colour: white & black

End Cap

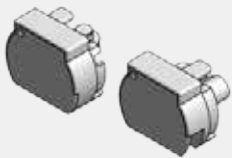

Slimline Vogue® End Caps

Dimensions: 38.5mm (1 9/16") x 27.34mm (1 1/8")
Colour: white, brown or black

Slimline Vogue Monocommand

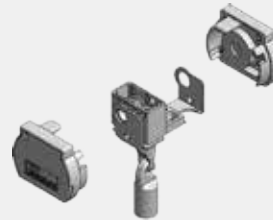

Alternative wand control - Child Safety Product

Colour: white, brown or black

Carrier Trucks

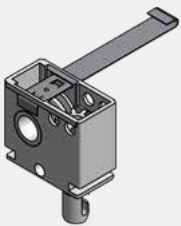

Spade Hook, self-aligning, 89mm For use with stainless steel spacer links

Spade Hook, fixed gear, 89mm For use with stainless steel spacer links

Truck Body: nylon, link: stainless steel
Dimensions: 24mm x 32mm x 12mm Colour: white, brown or black

Slimline Vogue Monocommand Wand



Available in lengths: 800mm, 1200mm or 2000mm

Colour: white or black

Rotation Chain



Available in nickel plated steel.

Cord Weight



Colour: white

VOGUE COMPONENTS

Louvre Inserts

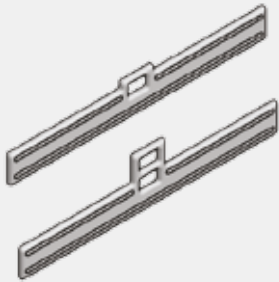

Double Slotted Hole, Plastic
89mm,
Colour: white & black

Stabalising Chain with C Clip



Available in Plastic
Sizes: 89mm,
Colour: white or black (plastic)

BRACKET OPTIONS

Shallow frame face fix brackets

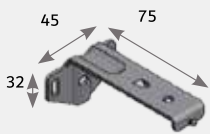

89mm
Mild steel, zinc plated and powder coated
Colour: white or brown

Dimensions: 45mm (1 1/2") x 32mm (1 1/4") x 75mm (3")

Extension Top fix brackets

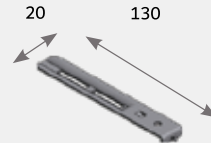

Mild steel, zinc plated and powder coated
Colour: white

Dimensions: short arm 20mm (3/4") x 130mm (5 1/8") long arm 20mm (3/4") x 165mm (6 1/2")

Top fix brackets

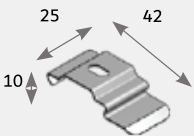

Mild steel, zinc plated and powder coated
Colour: white, brown or silver

Dimensions: 25mm (1") x 10mm (3/8") x 32mm (1 1/4")

Side fix brackets

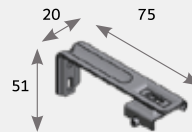

89mm
Mild steel, zinc plated and powder coated
Colour: silver

Dimensions: 20mm (3/4") x 51mm (2") x 75mm (3") for 89mm (3 1/2") louvres.
20mm (3/4") x 51mm (2") x 89mm (3 1/2") for 127mm (5") louvres

Adjustable face fix brackets

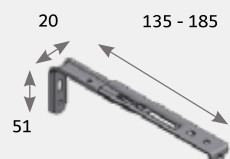

135mm - 185mm
Mild steel, zinc plated and powder coated
Colour: white

Dimensions: short arm 20mm (3/4") x 51mm (2") x 135 - 185mm (5 1/4" x 7 1/4"),]

BRACKET OPTIONS

Shallow Frame Face Fix Brackets

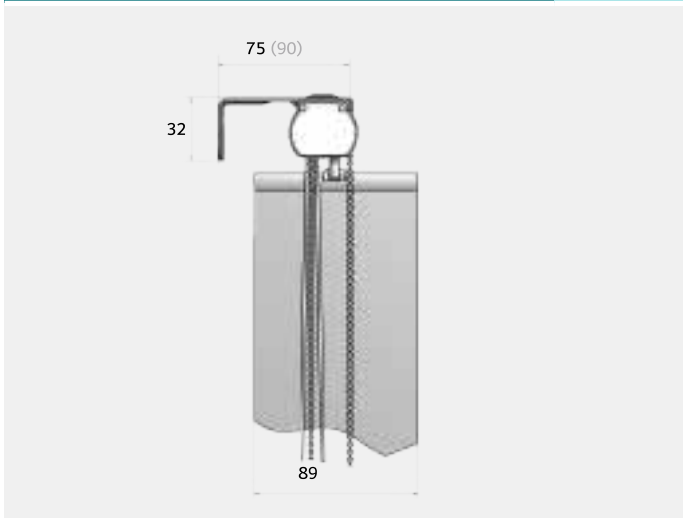

Adjustable Face Fix Brackets

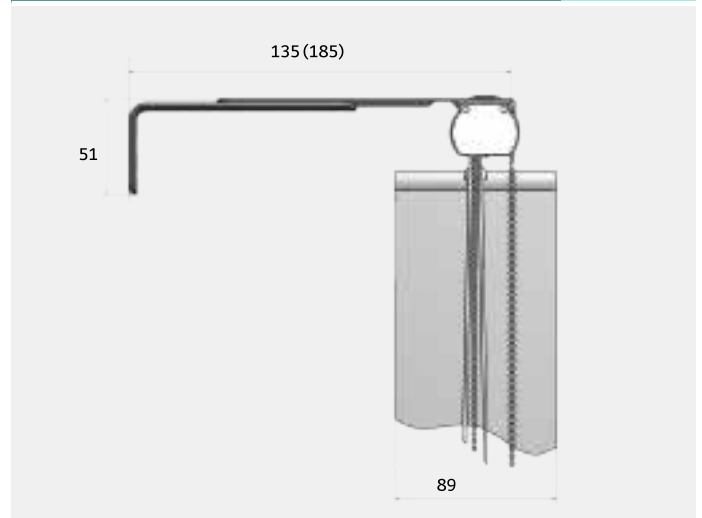

Top Fix Brackets



Extension Top Fix Brackets

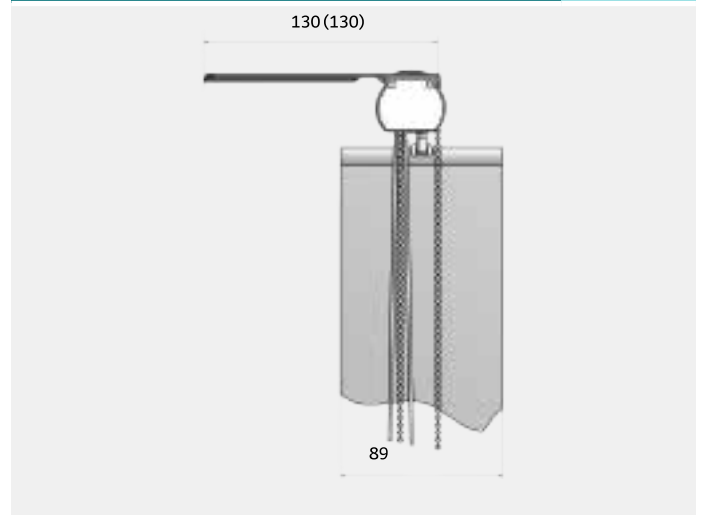

Top Fix Brackets (spring)

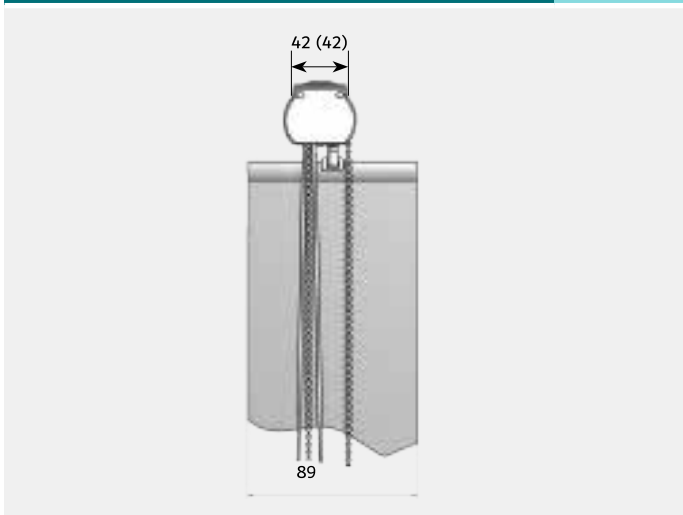

Side Fix Brackets

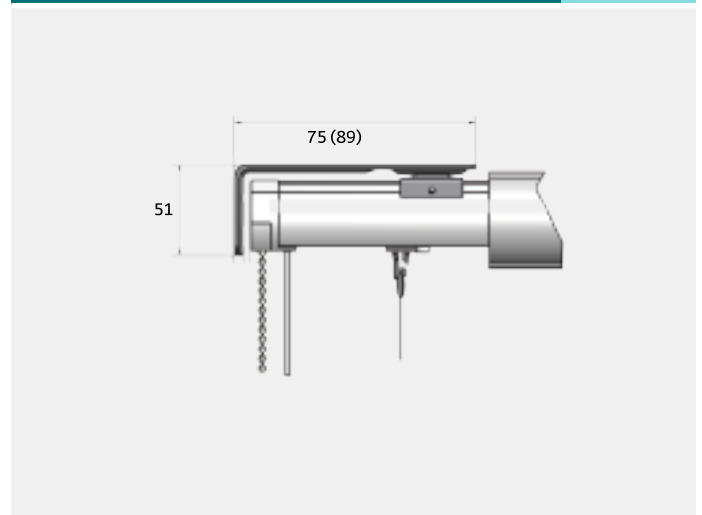

Shaped Blind Options

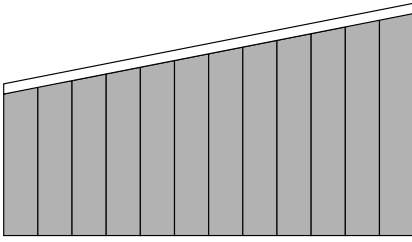

ANGLED TOP

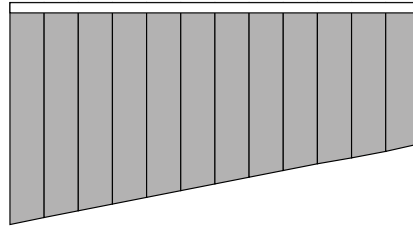

ANGLED BOTTOM

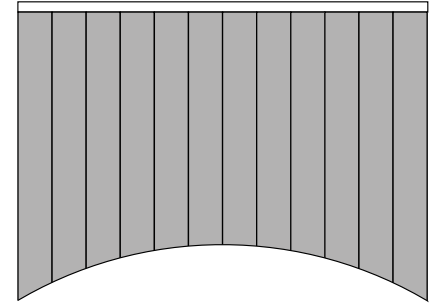

CURVED BOTTOM

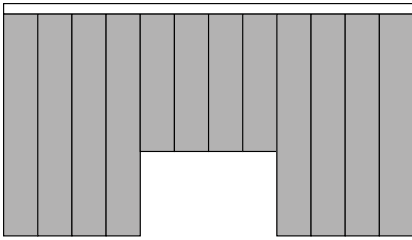

SHAPED

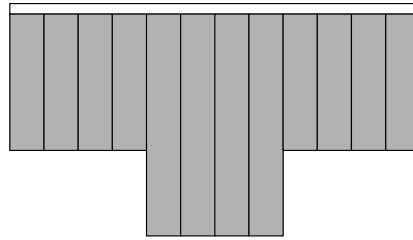

STEPPED BOTTOM EDGE

Bunching Options

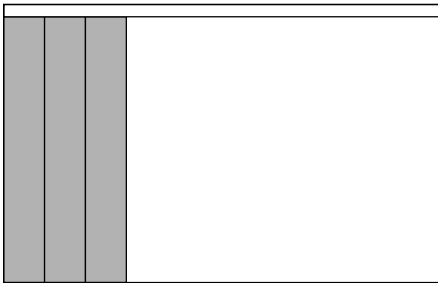

LEFT BUNCH

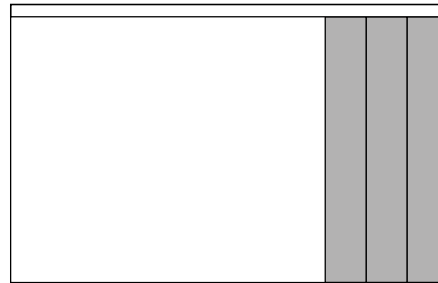

RIGHT BUNCH

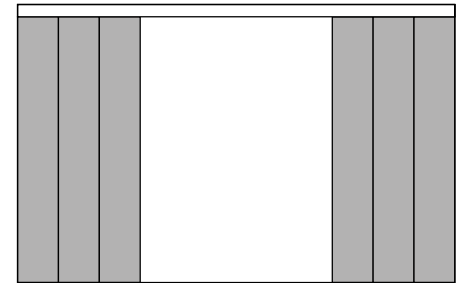

SPLIT BUNCH

Bunching	89mm (3 1/2") Louvres
One Way	225mm (8 3/4") for 1st metre (3'3") width of blind. 175mm (7") for each additional metre
Split	225mm (8 3/4") for 1st metre (3'3") width of blind. 175mm (7") for each additional metre
Centre	165mm (6 1/2") for 1st metre (3'3") width of blind. 165mm (6 1/2") for each additional metre

Blindtex **UAE**
Area E4 Unit 016
SAIF Zone Sharjah – United Arab Emirates
Tel: +971 65578051
Email: sales@blindtex.com

Blindtex **UK**
4A Wigan Road
Bolton
Lancashire
BL3 5PZ
Phone: 01204 655000

www.blindtex.com



A BRAND OF **INNOV8** PRODUCTS