

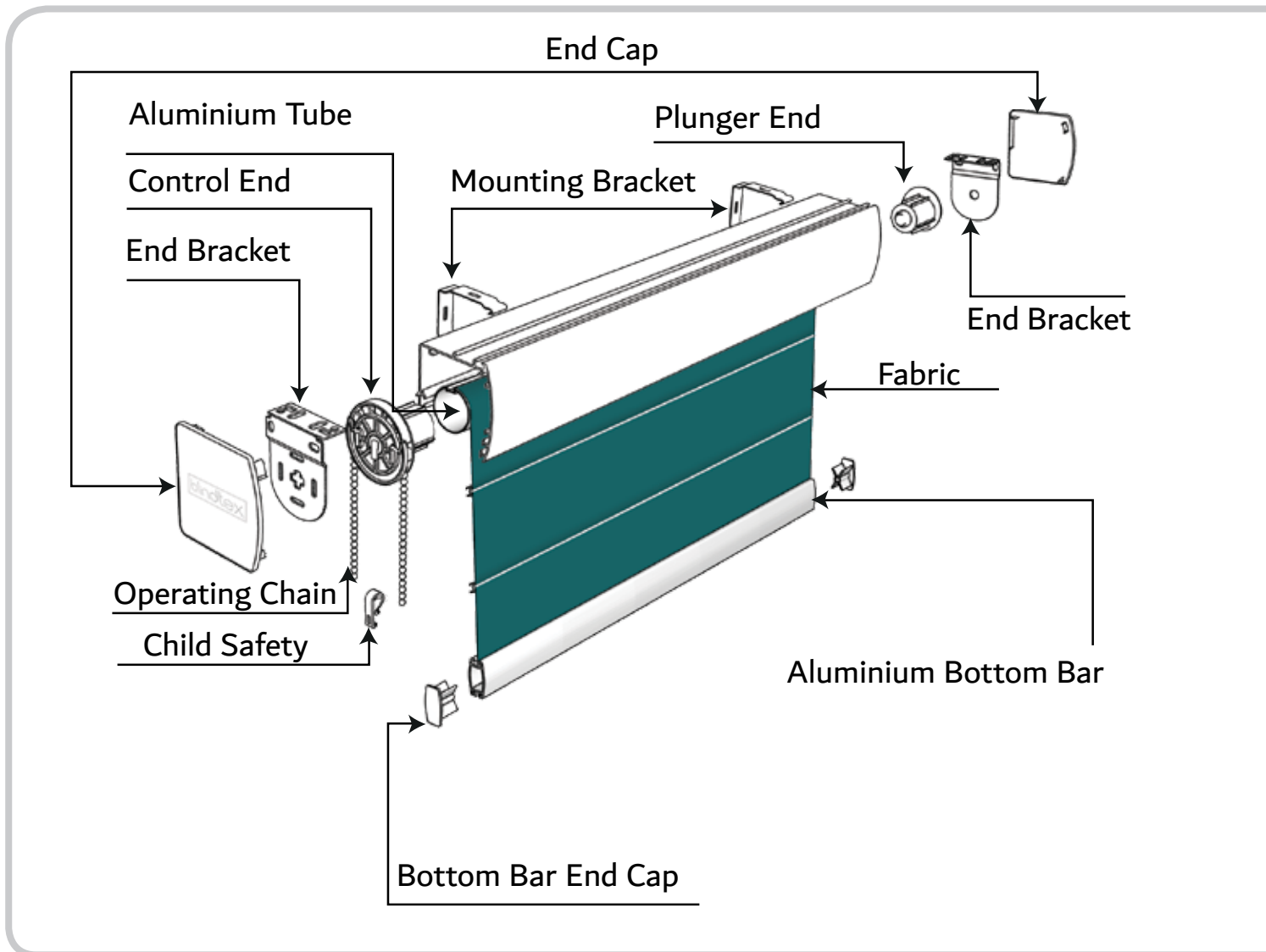

# ROMEX BLIND TECHNICAL DRAWING



# ROMEX SYSTEM COMPONENTS

**Tube**

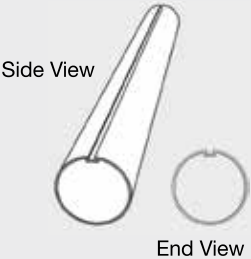

Side View  
End View

The design allows for full integration of the selected fabric and also provides maximum resistance to tube deflection.

**Brackets (metal)**

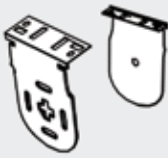

White painted steel. The mounting brackets are designed to allow top, face or side fix installations. The bracket design enables quick and simple installation whilst minimising the light gap between the blind and any recess. Extension brackets are available if required. Brackets are colour keyed to operating system colour. Covers for the mounting brackets are available to suit each size.

**Control End / Plunger End**

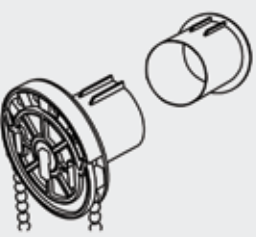

Side action control unit & plunger in engineered plastic. Unit locks into brackets. Clutch type suitable up to 9kg weight. Can be left or right control.

**Chain**



Chain (Steel, Nickel Chrome Plated)

**Bottom Bar**



Extruded PVC bottom bar in UPVC with 4 locking channels for fabrics & trims. 30mm x 16mm. Weight per linear meter - 200gm

Aluminium anodized bottom bar profile with color matched end caps. 29 x 19mm with fabric locking slot. Weight per linear meter - 460gm

**Bottom Bar End Caps**

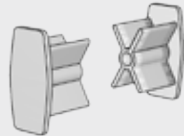

Co-ordinating end caps apply the appropriate finish to the bottom rail assembly.

**Cord Guide Clip**



**Bell Connector**

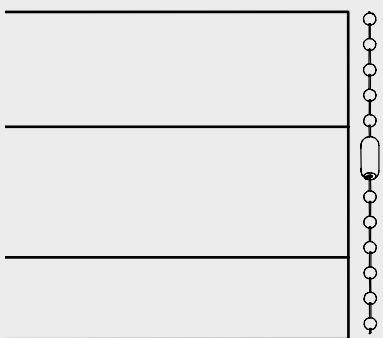

# CASSETTE SYSTEM

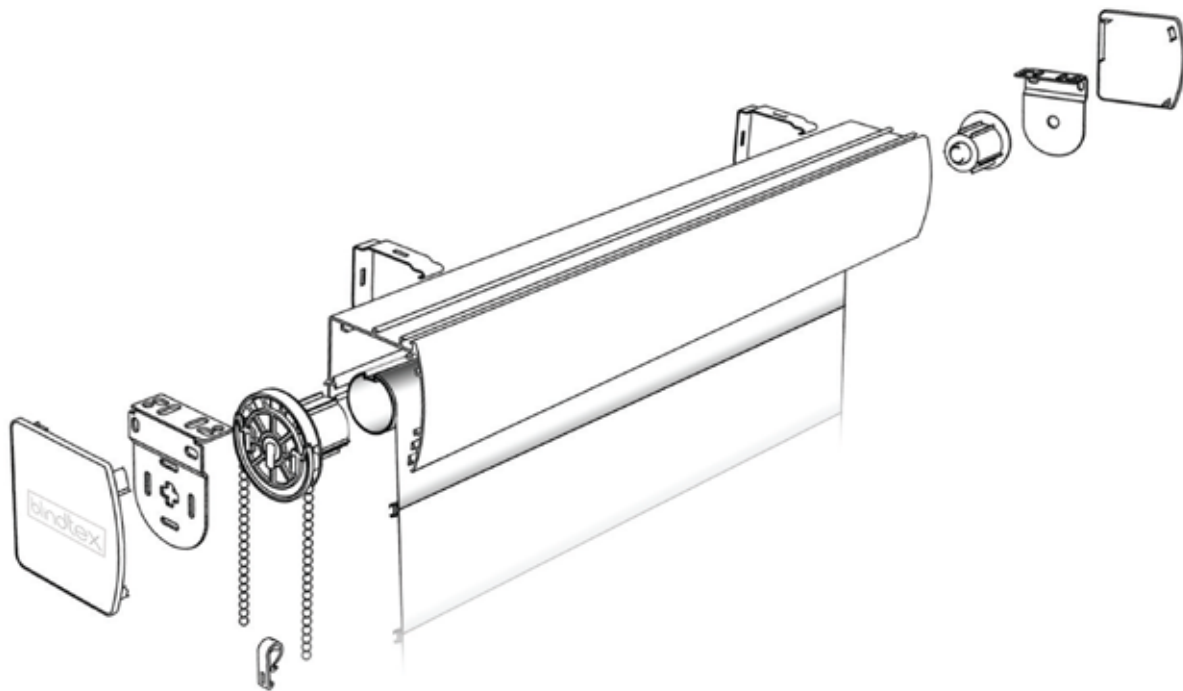

## Cassette System

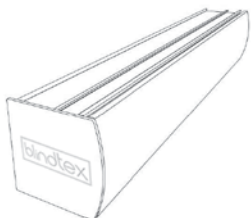

Cassette system, allows quick and easy mounting in either top fix or face position. Our patented design allows for reverse rolling and covering with matching or contrasting fabric.

## Mounting Brackets

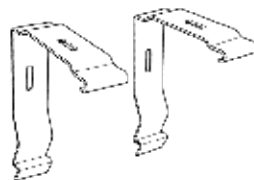

Stove enamelled finish to galvanized steel. The mounting brackets are designed to allow top, face or side fix installations. The bracket design enables quick and simple installation whilst minimizing the light gap between the blind and any recess.

## P Clip



A P-Clip keeps the chain close to the wall which makes it hard for children to gain access to it and become entangled.

## Plastic End Cap

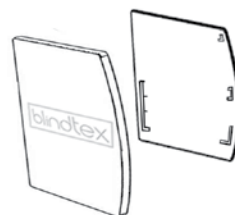

# CASSETTE DIMENSIONS

## Cassette System Small

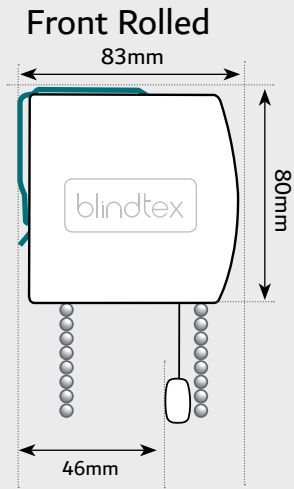

### Front View

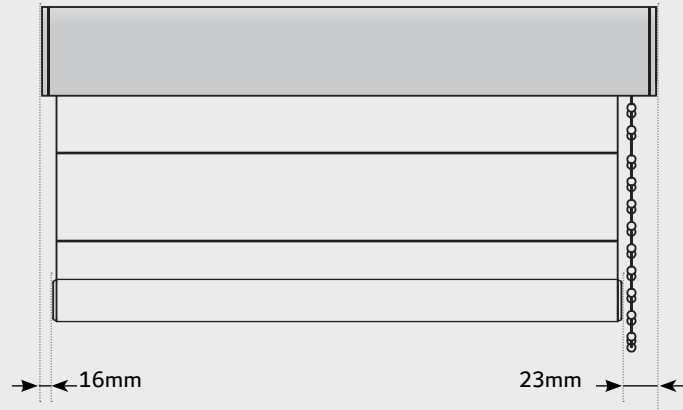

All component parts and fabric are enclosed within a rounded resulting in a compact, robust system with a streamlined appearance. Fast, multiple installations can be achieved using top fix or face fix brackets that can be fitted along the whole length of the cassette. The snap fix fascia can be white or graphite or with a matching fabric profile.

## Cassette System Medium

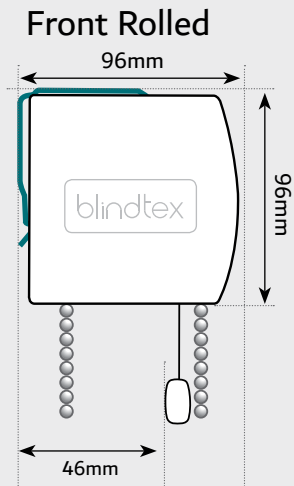

### Front View

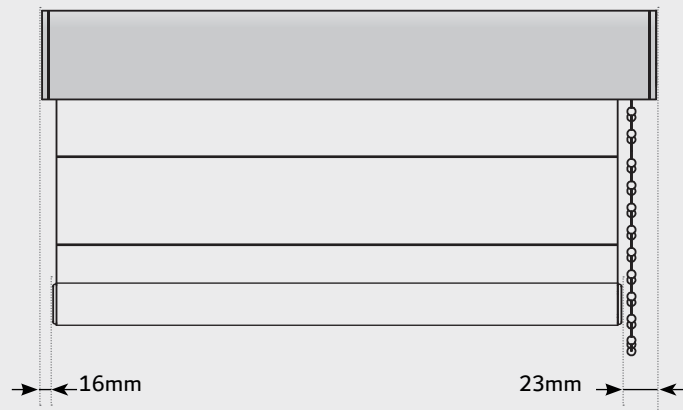

All component parts and fabric are enclosed within a rounded resulting in a compact, robust system with a streamlined appearance. Fast, multiple installations can be achieved using top fix or face fix brackets that can be fitted along the whole length of the cassette. The snap fix fascia can be white or graphite or with a matching fabric profile.



# CASSETTE DIMENSIONS

## Cassette System Large

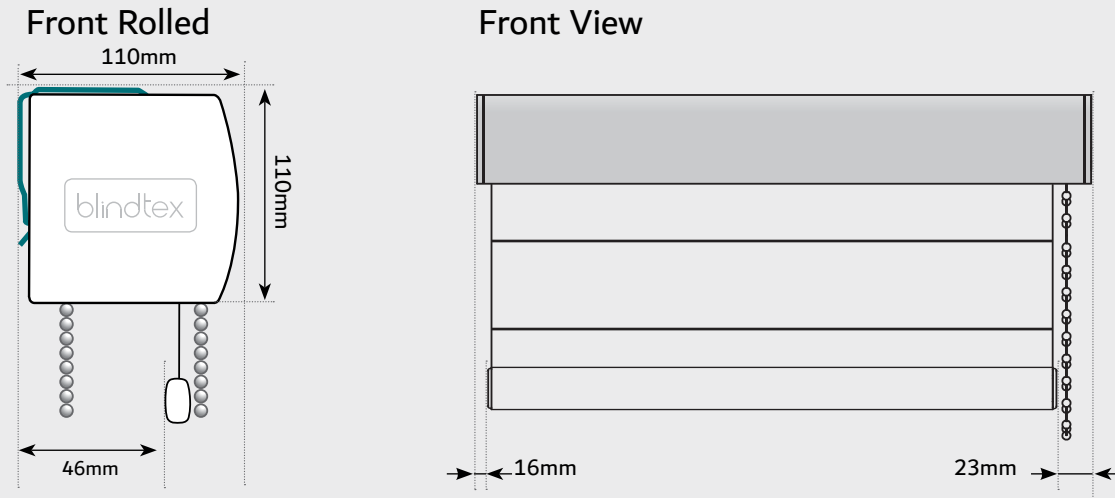

All component parts and fabric are enclosed within a rounded resulting in a compact, robust system with a streamlined appearance. Fast, multiple installations can be achieved using top fix or face fix brackets that can be fitted along the whole length of the cassette. The snap fix fascia can be white or graphite or with a matching fabric profile.

# ROMEX BLIND SYSTEM COMPATABILITY CHART

Tube/Mechanism	Side Winder			Battery Motor				Wired Motor					
	Small	Medium	Large	Blindtex Small	Blindtex Medium	Blindtex Large	Somfy Sonesse 30	Blindtex Medium Large	Blindtex Extra Large	Somfy Optuo 40	Somfy Sonesse 40	Somfy Sonesse 50	Somfy Altus 52
32mm Single Slot	*			*									
38mm Double slot		*		*									
45mm Tripple Slot Tube			*		*								
40mm Tripple Octagonal						*	*	*		*	*		
57mm Tripple								*	*			*	*
<b>Cassette</b>													
Small	*												
Medium		*		*			*			*	*	No Cassette Compatible	No Cassette Compatible
Large			*		*	*	*	*	*	*	*		

Blindtex **UAE**  
Area E4 Unit 016  
SAIF Zone Sharjah – United Arab Emirates  
**Tel:** +971 65578051  
**Email:** sales@blindtex.com

Blindtex **UK**  
4A Wigan Road  
Bolton  
Lancashire  
BL3 5PZ  
**Phone:** 01204 655000

[www.blindtex.com](http://www.blindtex.com)



A BRAND OF **INNOV8** PRODUCTS